



PAR lite

Photosynthetic Active Radiometer

Instruction Manual

**Reading this entire manual is recommended for full
understanding of the use of this product**



The exclamation mark within an equilateral triangle is intended to alert the user to the presence of important operating and maintenance instructions in the literature accompanying the instrument.

Should you have any comments on the product or this manual we will be pleased to receive them at:

Kipp & Zonen B.V.
Delftechpark 36
2628 XH Delft Holland
P.O. Box 507 2600 AM Delft Holland
Phone +31 (0)15 2755210
Fax +31 (0)15 2620351
Email info@kippzonen.com
Web www.kippzonen.com

Kipp & Zonen reserve the right to make changes in the specifications without prior notice.

WARRANTY AND LIABILITY

the Kipp & Zonen guarantees that the product delivered has been thoroughly tested to ensure that it meets its published specifications. The warranty included in conditions of delivery is valid only if the product has been installed and used according to the instructions supplied by Kipp & Zonen.

User made modifications can affect the validity of the CE declaration.

Kipp & Zonen shall in no event be liable for incidental or consequential damages, including without limitation, lost profits, loss of income, loss of business opportunities, loss of use and other related exposures, however caused, arising from the faulty and incorrect use of the product.

COPYRIGHT® 2004 KIPP & ZONEN

All rights reserved. No part of this publication may be reproduced, stored in a retrieval system or transmitted in any form or by any means, without permission in written form from the company.

Manual version 0706

Contents

1	General information.....	3
1.1	<i>Five minutes user guide</i>	4
2	Sensor properties	7
2.1	<i>Electrical.....</i>	7
2.2	<i>Spectral</i>	9
2.3	<i>Directional / Cosine response</i>	10
2.4	<i>List of specifications</i>	12
2.5	<i>Dimensions.....</i>	14
2.6	<i>Expected output levels</i>	15
3	Calibration	17
4	Installation and maintenance	19
4.1	<i>Recalibration</i>	20
4.2	<i>Adjustment of calibration factor.....</i>	20

4.3	Measuring modulated light	21
5	Trouble shooting.....	23
6	Delivery	25
7	Accessories.....	27

1 General information

The PAR *LITE* is an instrument for the measurement of Photosynthetic Photon Flux Density. In practise this quantity is called PAR, which stands for Photosynthetically Active Radiation. This measurement represents the number of photons between 400 and 700 nm incident per square meter per second. These photons can be used by green plants for the process of photosynthesis. PAR *LITE* measures the photons that are received from the entire hemisphere (180 degrees field of view). The output is expressed in micro mol per second per square meter.

The PAR *LITE* is designed for continuous outdoor use. Its calibration is valid for natural sunlight, for artificial light it will be less accurate. See the section on spectral sensor properties and calibration.

In its most frequent application the PAR sensor is used for agrometeorological and horti-culture applications. Typically it will be installed in a meteo-mast and face upwards. It can however be used to measure in an inverted or in a tilted position.

Contrary to similar designs of other brands, the PAR *LITE* is not equipped with a level. The reason is that for the kind of accuracy that this sensor can offer, leveling does not need to be accurate. The levelling with a level instrument over the rim/diffuser during installation suffices. A check on the levelling

can be done in the same way. A levelling fixture is available as an option.

The PAR-LITE fully complies **CE** with directive 89/336/EEC

1.1 Five minutes user guide

Requirements:

1. PAR *LITE*
 2. voltmeter with a range from 0 to 20 millivolt and an
 3. input impedance of more than 50 k Ω
 3. light
- Connect the white wire to the voltmeter+, the green wire to the voltmeter-, the shield to the ground.
 - Position the instrument as such that the sensor is parallel to the surface that you want to investigate.
 - Put the voltmeter to the most sensitive range.
 - Darken the sensor. The signal should read zero.
 - Expose the sensor to light. The signal should give a positive reading.
 - Adjust the voltmeter range in such a way that the expected full scale output of the PAR *LITE* fits the full scale input of the voltmeter. This can be done on theoretical considerations. (When the maximum expected radiation outdoors is 2 000 micro mol per second per square metre, and the sensitivity of the PAR *LITE* is 5 microvolts per micro mol per second per square metre, the expected output range of the PAR *LITE* is 2000 times 5 makes 10000 microvolts or 10 millivolts.) Please note that the calibration is valid for natural sunlight only.

- Calculate the radiation intensity by dividing the PAR *LITE* output (10 millivolts) by the calibration factor ($5 \mu\text{V}/\mu\text{mol}/\text{s}\cdot\text{m}^2$).
- For permanent installation mounting should be done using the holes through the PAR *LITE* body, or through the holes in the optional levelling fixture. The sensor should be mounted in a field which is free from obstructions. Unless this is unavoidable, no shadow should be cast upon it.
- Maintenance: the sensor should be kept clean, using water or alcohol.
- Recalibration is suggested every two years, preferably by letting a higher standard run parallel to it during two different days, a clear day and a cloudy day and by comparing the daily totals.

2 Sensor properties

The PAR *LITE* consists of a photodiode, filters, a diffuser, a housing and a cable.

The photodiode is shunted by a resistance. This is done to generate a voltage output. Most electrical specifications are determined by the photodiode and the resistor. Spectral specifications are determined by the photodiode, the filters and the diffuser material. The diffuser ensures a field of view of 180 degrees, and angular characteristics fulfilling the so-called cosine response.

2.1 Electrical

The electrical circuit of the PAR *LITE* is drawn in figure 1. The nominal output resistance of the PAR *LITE* is 240 Ω . This implies that the input impedance of the readout equipment should be at least 30 k Ω in order to make an error of less than 1 percent.

Cable can be extended without problems to a length of 100 metres, provided that cable resistance is less than 0.1 percent of the input impedance of the readout equipment.

The electrical sensitivity of the photodiode changes with the temperature. A typical value for this is -0.1 percent change per degree Celsius.

Calibration is done at approx. 25° Celsius.

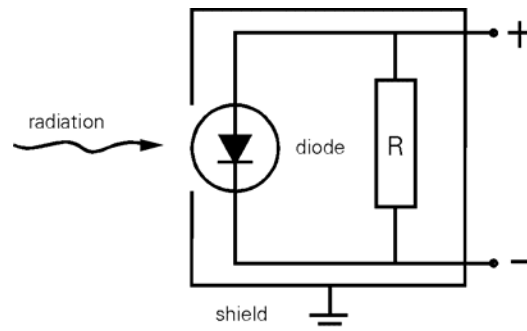

Figure 1 Electrical circuit of the PAR LITE, white +.

2.2 Spectral

The spectral properties of the PAR *LITE* are mainly determined by the properties of the photodiode and the filter. The spectral sensitivity is indicated in figure 2.

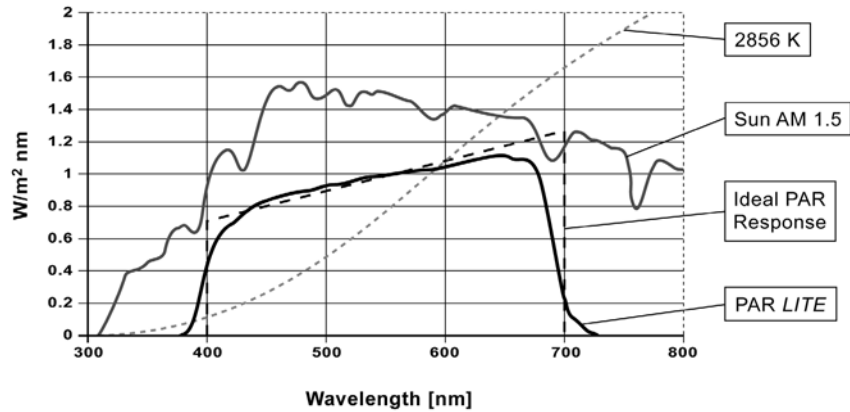

Figure 2. The relative spectral sensitivity of the PAR *LITE* sensor and the ideal PAR spectral response together with the spectrum of the sun under a clear sky (airmass 1.5) and the relative spectrum of a lamp with a colortemperature of 2856 K.

The sensor follows more or less the characteristic of a so-called quantum response between 400 and 700 nm. This is said to be the spectral area which is utilised by plants for photosynthesis. For the photosynthesis each photon has an equal significance. Because photons of a lower wavelength

have higher energy content, the spectral sensitivity of a PAR sensor has to be low for low wavelengths and higher for higher wavelengths. This explains the inclination of the spectral sensitivity curve.

The PAR *LITE* has been calibrated for solar radiation under clear sky conditions. The spectrum under these circumstances is also drawn in figure 2.

Some plants however are grown under lamps. The spectral emission of this lamps is mainly in the wavelength range from 500 – 600 nm. This implies that actually the mean spectral sensitivity of the PAR *LITE* in the range of 500 – 600 nm should be used. This sensitivity can differ from the sensitivity for daylight, which is also determined by the individual bandwidth of the PAR *LITE* sensor. Deviations can be of the order of magnitude of $\pm 5\%$. Read also chapter 3, Calibration, for this matter.

2.3 Directional/Cosine response

The measurement of radiation received by a surface (also called irradiance or radiative flux) is laid down in two detector specifications: that the detector has a correct spectral response and that it has a field of view of 180 degrees.

Another way of expressing the latter directional properties is to say that the sensor has to comply with the cosine response.

A perfect cosine response will show maximum sensitivity at an angle of incidence of 0° (perpendicular to the sensor surface) and zero sensitivity at an angle of incidence of 90° (radiation passing over the sensor surface). In between 0° and 90° the

sensitivity should be proportional to the cosine of the angle of incidence. Figure 3 shows the behaviour of a typical PAR *LITE*. The vertical axis shows the deviation from ideal behaviour, expressed in percentage of the ideal value.

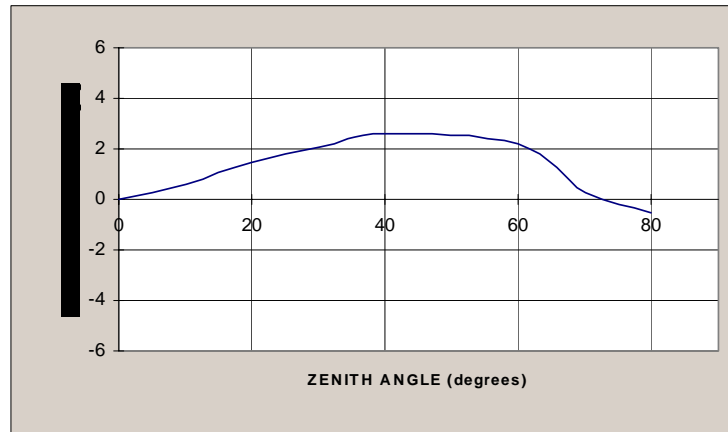

Figure 3. *The directional response or cosine response of the PAR LITE. On the horizontal axis the zenith angle
On the vertical axis the percentage deviation from ideal cosine behaviour.
The curve can lift or fall for different azimuth (+ or - 2.5% at 70° zenith angle).*

2.4 List of specifications

Electrical

- Impedance (nominal): 240 Ω
- Response time: < 0.1 s
- Sensitivity: 4 - 6 $\mu\text{V}/\mu\text{mol}/\text{s}\cdot\text{m}^2$
- Expected signal range under atmospheric conditions: 0 – 12 mV
- Non-stability: within $\pm 2\%$ /year
- Non linearity: within $\pm 1\%$
up to 10000 $\mu\text{mol}/\text{s}\cdot\text{m}^2$
- Temperature dependence of sensitivity: within $\pm 0.2\%/^{\circ}\text{C}$
(-0.1% typ.)

Spectral

- Detector type: Silicon photodiode plus filters
- Spectral range (nominal): 400 - 700 nm
- Cut on (50 %): 400 \pm 15 nm
- Cut off (50 %): 700 \pm 15 nm
- Quantumresponse match error (450 – 650 nm) within $\pm 10\%$

Directional

- Cosine corrected between 0 and 80°
Error up to 80° angle of incidence, within ± 10 %
- azimuth error (at 70° angle of incidence): < 5 %pp
- Tilt response: no error

Mechanical

- Material of housing: Anodized Aluminium
- Material of cable: Poly Urethane
- Weight: 110 g
- Cable length: 3 metres
- Dimensions see figure 4

Environmental

- Operating temperature range: -30 - +70 °C
- Humidity: 0 - 100 % RH

2.5 Dimensions

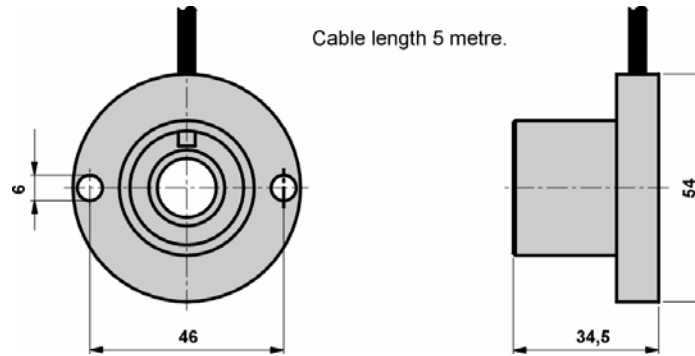

Figure 4. The dimensions of the PAR LITE in mm, white lead positive, green lead negative.

2.6 expected output levels

Cloud condition	Pyranometer reading W/m^2	PAR sensor reading $\mu mol/s.m^2$	$\mu mol/W.s$ +/- 10%
Cloudless	Typ 0 to 1300	Typ 0 to 2600	2,0
Cloudy	Typ 0 to 500	Typ 0 to 1250	2.5

Table 1: Conversion from W/m^2 to $\mu mol/s.m^2$ under cloudless and cloudy conditions. The table serves as a rough cross-check when also measurements of the solar irradiance in W/m^2 are available.

Cloud condition	Pyranometer daily total W.h/m ²	PAR sensor daily total mol/m ²	
Cloudless	Up to 11000	Up to 80	
Cloudy	Up to 4500	Up to 40	

Table 2: expected daily totals; the figures are indicative

3 Calibration

The PAR *LITE*'s are calibrated against a reference PAR *LITE* in a parallel beam of light from a Xenonlamp. In the wavelength range of 400 – 700 nm the Xenonlampspectrum is comparable with natural sunlight under clear sky conditions. Further calibration conditions are: temperature 25 degrees Celsius, 400 $\mu\text{mol/s.m}^2$ and normal incidence radiation.

The reference PAR *LITE* is calibrated periodically against a standard of spectral irradiance of Osram type Wi 41/G, which on his turn is calibrated at the dutch standard laboratory NMI. The resulting sensitivity is corrected to hemispherical solar radiation at airmass 1.5. The spectrum for airmass 1.5 was taken from the international standard ISO 9845-1.

By this way we state that the PAR *LITE* sensitivity is most correct for hemispherical solar radiation with airmass 1.5 spectrum (solar zenith angle 37°). Under artificial light (lamps) of narrower bandwidth than 400-700 nm PAR *LITE*'s with the same sensitivity figure can indicate different intensities, because the bandwidth of the individual PAR *LITE*'s can differ ± 30 nm.

This bandwidth played a role during the calibration under light with a broad spectrum (Xe), but plays no role by the narrow spectrum of some lamps (Na, Hg).

4 Installation and maintenance

When installed permanently, the PAR *LITE* can be attached to its mounting platform using the holes that are drilled through the body. The holes are standardised to Kipp & Zonen design. Leveling can be done with a level instrument over the rim/diffuser.

Preferred orientation is with the cable pointing away from the equator (this prevents excessive heating of the leads). When installed on a mast, preferred orientation is such that no shadow is cast on the PAR *LITE* during any time of the day. On the northern hemisphere this implies that the PAR *LITE* should be south of the mast.

The PAR *LITE* can be used to measure reflected radiation, for instance when pointed towards the earth in the inverted position. When measuring reflected radiation it is advised to measure at a height H of at least 1.5 meters above the surface in order to avoid shading effects and to promote spatial averaging. (99% of the signal is from a field with radius $10 \cdot H$) The PAR *LITE* is an all weather instrument.

Once installed the PAR *LITE* needs little maintenance. It is suggested to clean the detector as part of a regular routine, using water or alcohol.

4.1 Recalibration

Recalibration is suggested every two years. This can be done in two ways. The first is by comparing with the measurement of a similar sensor at the same site. Preferably daily totals of several days (clear and overcast) should be compared.

Calibration factor could be corrected if results differ by more than five percent.

The second way is to let a recalibration be performed at the PAR *LITE* factory.

4.2 Adjustment of calibration

If necessary, the sensitivity of the PAR *LITE* can be adapted. This can be done by soldering a resistor between the + (white) and - (green) output wires. In this way the internal resistance is shunted. Suppose, the internal (load) resistance R_l is 270 Ω . To be sure, measure the impedance of the PAR *LITE* with an Ohmmeter, in the correct direction. (reverse voltage on photodiode). Neglecting the cable-resistance, the cable resistance is 0.12 Ω per meter a shuntresistor R_p of 2430 Ω reduce the sensitivity by a factor of 0.9. A shunt resistor of about 2430 Ω can be made with a 2700 Ω resistor shunted by a resistor of 24 k Ω

The general formula is: $S_{new} = S_{old} \cdot R_p / (R_l + R_p)$

4.3 Measuring modulated light

In the same way it is possible to shunt the PAR *LITE* with a capacitor. This can be necessary when modulated light must be measured. The PAR *LITE* has a response time much smaller than 0,1s and much read-out equipment cannot handle the resulting voltage pulses. At principle you must bring the RC time above the period time of the lightpulses to get a smooth signal. Due to the relative low impedance of the PAR *LITE* this need big capacitors. which can be problematic because electrolytic capacitors are often useless due to their battery effect. So use polyester, ceramic, etc types.

5 Trouble shooting

If your PAR LITE does not seem to work at all, please follow the following procedure:

- Check if the PAR *LITE* reacts to light, using the procedure in the "five minutes user manual".
- No result? Measure the impedance of the sensor across the white and the green wires in the dark. With reverse voltage across the photodiode this should be e.g. 240 Ohms. If it is close to five Ohms, there is a short circuit. If it is infinite, the circuit is blown. With forward voltage across the photodiode you will mostly measure a resistance < 240 Ohms if the photodiode-circuit is OK.

If the PAR LITE shows bigger or smaller results than expected, the following questions might help you out:

- Are you measuring under natural sunlight? If so the maximum expected radiation is 2600 $\mu\text{mol/s.m}^2$. Under lamps this might be sometimes more but often much less.
- Are you correcting for the calibration factor? Please note that this factor is an individual property and is different for each sensor. Do you divide by the factor? Yes? This is correct.
- What is the input impedance of your readout equipment? It should preferably be more than 30 kilo-

ohm. If smaller than 3000 ohm you will notice errors of already -10 %.

- Is your readout equipment properly calibrated?

If still no satisfactory answer is found, please contact your supplier.

6 Delivery

Delivery includes:

1 PAR <i>LITE</i> sensor	0348900
1 calibration certificate	-----
1 manual	0348200

7 Accessories

CLF1 levelling fixture 0338700



**KIPP &
ZONEN**
SINCE 1830

Our customer support remains at your disposal for any maintenance or repair, calibration, supplies and spares.

Für Servicearbeiten und Kalibrierung, Verbrauchsmaterial und Ersatzteile steht Ihnen unsere Customer Support Abteilung zur Verfügung.

Notre service 'Support Clientèle' reste à votre entière disposition pour tout problème de maintenance, réparation ou d'étalonnage ainsi que pour les accessoires et pièces de rechange.

Nuestro apoyo del cliente se queda a su disposición para cualquier mantenimiento o la reparación, la calibración, los suministros y reserva.

HEAD OFFICE

Kipp & Zonen B.V.

Delftechpark 36, 2628 XH Delft
P.O. Box 507, 2600 AM Delft
The Netherlands

T: +31 (0) 15 2755 210

F: +31 (0) 15 2620 351

info@kippzonen.com

SALES OFFICES

Kipp & Zonen France S.A.R.L.

7 Avenue Clément Ader
ZA Ponroy - Bâtiment M
94420 Le Plessis Tréville
France

T: +33 (0) 1 49 62 41 04

F: +33 (0) 1 49 62 41 02

kipp.france@kippzonen.com

Kipp & Zonen Asia Pacific Pte. Ltd.

81 Clemenceau Avenue
#04-15/16 UE Square
Singapore 239917

T: +65 (0) 6735 5033

F: +65 (0) 6735 8019

kipp.singapore@kippzonen.com

Kipp & Zonen USA Inc.

125 Wilbur Place
Bohemia
NY 11716
United States of America

T: +1 (0) 631 589 2065

F: +1 (0) 631 589 2068

kipp.usa@kippzonen.com

Go to www.kippzonen.com for your local distributor or contact your local sales office

Passion for Precision