

CGR4 and SGR4 Pyrgeometers

Operational Manual



Copyright © OTT HydroMet B.V.

OTT HydroMet B.V.
Delftechpark 36
2628 XH Delft
The Netherlands

+31 15 2755 210
solar-info@otthydromet.com
www.otthydromet.com

All rights reserved.

All content is the intellectual property of OTT HydroMet. Reprinting, duplication and translation (even as excerpts) are only permitted with the prior written consent of OTT HydroMet.

Subject to technical change.

Table of contents

1	Scope of supply _____	5
2	Order numbers and variant code _____	6
2.1	Product variants _____	6
2.2	Accessories and spare parts _____	6
3	About this manual _____	7
3.1	Other applicable documents _____	7
3.2	General signs and symbols _____	7
3.3	Explanation of warnings _____	7
4	General safety instructions _____	8
4.1	Intended use _____	8
4.2	Potential misuse _____	8
4.3	Personnel qualification _____	8
4.4	Operator obligations _____	8
4.5	Personnel obligations _____	8
4.6	Correct handling _____	9
4.7	Certification _____	9
5	Product description _____	10
5.1	Design and function _____	10
5.2	Product overview _____	10
6	Transport, storage, and unpacking _____	12
6.1	Transport _____	12
6.2	Storage _____	12
6.3	Unpacking _____	12
7	Installation _____	13
7.1	Mechanical installation _____	13
7.1.1	Preparatory work _____	13
7.1.2	Required tools and aids _____	13
7.1.3	Installation for measuring long-wave downward radiation _____	13
7.1.4	Installation for measuring upward long-wave radiation _____	15
7.1.5	Installation for shaded measuring downward long-wave radiation _____	15
7.1.6	Installation for measuring net long-wave radiation _____	16
7.2	Electrical installation _____	17
7.2.1	Electrical connections of CGR pyrometers _____	17
7.2.2	Electrical connections of SGR pyrometers _____	19
7.2.3	Grounding instrument _____	21

8	Commissioning	22
8.1	Instrument set-up	22
9	Maintenance	23
9.1	Maintenance schedule	23
9.2	Replacing desiccant	23
10	Troubleshooting	24
10.1	Error elimination	24
11	Repair	25
11.1	Customer support	25
12	Notes on disposing of old devices	26
13	Technical data	27
13.1	Optical and electrical data	27
13.2	Dimensions and weight	28

1 Scope of supply

The following items are included with delivery:

- Pyrgeometer
- Sun shield
- Calibration certificate and temperature response report
- Instruction sheet
- Pyrgeometer fixing kit
- 2 desiccant bags (CGR4 only)

2 Order numbers and variant code

2.1 Product variants

Variant	Order number
CGR4 Pyrgeometer, 10 K, no plug, no cable	0363900-010
CGR4 Pyrgeometer, Pt-100, no plug, no cable	0363900-020
SGR4-V Smart Pyrgeometer, 0 to 1 V version, no plug, no cable	0376900-100
SGR4-A Smart Pyrgeometer, 4 to 20 mA version, no plug, no cable	0376900-200

2.2 Accessories and spare parts

Infra red measurement

Item	Order number
SOLYS Gear Drive Sun Tracker	0381900
SOLYS2 Sun Tracker	0367900-001

Ventilation

Item	Order number
CVF 4 Ventilation Unit, no plug, no cable	0378910-000

Mountings

Item	Order number
CMB1 Mounting Bracket	0369701
CMF4 Mounting Fixture	0362703

Data logging

Item	Order number
LogBox SE Data Logger	3303096
PMU485 Smart Setup Hub converts USB to RS-485 and 12 V DC output for Smart and DustIQ setup and upgrade	0382460
Smart Powered Hub, for up to 6 smart instruments, with integrated AC to 24 V DC power supply	0382440

Cables

Item	Order number
10 m cable, pre-wired with waterproof 8-pin plug	0362621
25 m cable, pre-wired with waterproof 8-pin plug	0362623
50 m cable, pre-wired with waterproof 8-pin plug	0362624

3 About this manual

3.1 Other applicable documents

The following documents contain further information on installation, maintenance and calibration:

3.2 General signs and symbols

The signs and symbols used in the operational manual have the following meaning:

Practical tip

 This symbol indicates important and useful information.

Action

- ✓ Prerequisite that must be met before performing an action.
 - ▶ Step 1
 - ⇒ Intermediate result of an action
 - ▶ Step 2
 - ⇒ Result of a completed action

List

- List item, 1st level
 - List item, 2nd level

3.3 Explanation of warnings

To avoid personal injury and material damage, you must observe the safety information and warnings in the operating manual. The warnings use the following danger levels:

WARNING

WARNING

This indicates a potentially hazardous situation. If the hazardous situation is not avoided, it may result in death or serious injuries.

CAUTION

CAUTION

This indicates a potentially hazardous situation. If the hazardous situation is not avoided, it may result in moderately serious or minor injuries.

NOTICE

NOTE

This indicates a situation from which damage may arise. If the situation is not avoided, products may be damaged.

4 General safety instructions

4.1 Intended use

The pyradiometer is used to measure long-wave atmospheric downward radiation outdoors.

4.2 Potential misuse

Any use of the product that does not comply with the intended use, be this intentional or negligent, is forbidden by the manufacturer.

- ▶ Use the product only as described in the operational manual.

4.3 Personnel qualification

The equipment described in this manual must be installed, operated, maintained and repaired by qualified personnel only.

- ▶ Obtain training from OTT HydroMet if necessary.

4.4 Operator obligations

The installer is responsible for observing the safety regulations. Unqualified personnel working on the product can cause risks that could lead to serious injury.

- ▶ Have all activities carried out by qualified personnel.
- ▶ Ensure that everybody who works on or with the product has read and understood the operational manual.
- ▶ Ensure that safety information is observed.
- ▶ File the operational manual together with the documentation of the entire system and ensure that it is accessible at all times.
- ▶ The operational manual is part of the product, forward the operational manual together with the product.

4.5 Personnel obligations

To avoid equipment damage and injury when handling the product, personnel are obliged to the following:

- ▶ Read the operational manual carefully before using the product for the first time.
- ▶ Pay attention to all safety information and warnings.
- ▶ If you do not understand the information and procedure explanations in this manual, stop the action and contact the service provider for assistance.
- ▶ Wear the necessary personal protective equipment.

4.6 Correct handling

If the product is not installed, used and maintained correctly, there is a risk of injury. The manufacturer does not accept any liability for personal injury or material damage resulting from incorrect handling.

- ▶ Install and operate the product under the technical conditions described in the operational manual.
- ▶ Do not change or convert the product in any way.
- ▶ Do not perform any repairs yourself.
- ▶ Get OTT HydroMet to examine and repair any defects.
- ▶ Ensure that the product is correctly disposed of. Do not dispose of it in household waste.

4.7 Certification

CE (EU)

The equipment meets the essential requirements of EMC Directive 2014/30/EU.

FCC (US)

FCC Part 15, Class "B" Limits

This device complies with part 15 of the FCC Rules. Operation is subject to the following two conditions:

1. This device may not cause harmful interference.
2. This device must accept any interference received, including interference that may cause undesired operation.

IC (CA)

Canadian Radio Interference-Causing Equipment Regulation, ICES-003, "Class B"

This Class B digital apparatus meets all requirements of the Canadian Interference-Causing Equipment Regulations.

5 Product description

5.1 Design and function

The instrument is a radiometer designed for measuring long-wave irradiance on a plane surface (radiant flux, W/m^2) which results from radiation incident from the hemisphere above the instrument.

The meniscus dome provides a 180° field of view with negligible directional response error. A hard-carbon coating on the outside of the dome smooths the spectral response and provides extra protection to the silicon surface. The excellent thermal stability of the dome construction and coupling to the instrument body eliminates the need for dome temperature measurements or dome shading. The integral bubble level is raised to the top of the housing and can be viewed without removing the snap-on sun shield.

The SGR4 pyrgeometer also has Modbus[®] interface, amplified analog output, improved response time and temperature corrected measurement data.

To prevent condensation on the inner side of the window, the SGR4 pyrgeometer has an internal desiccant that last up to 10 years. The desiccant of the CGR4 pyrgeometer is located in a drying cartridge and must be replaced regularly.

5.2 Product overview

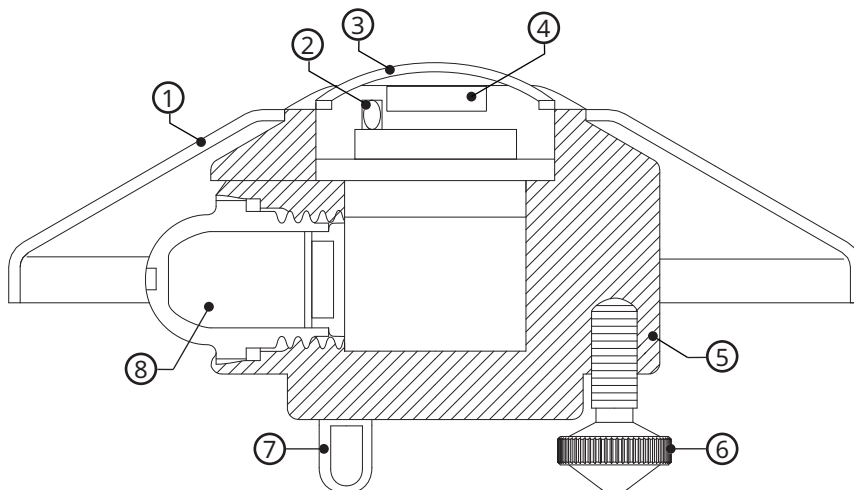

CGR4 Pyrgeometer

1	Sun shield	5	Housing
2	Body temperature sensor	6	Adjustable feet
3	Silicon window	7	Fixed foot
4	Thermopile detector	8	Drying cartridge

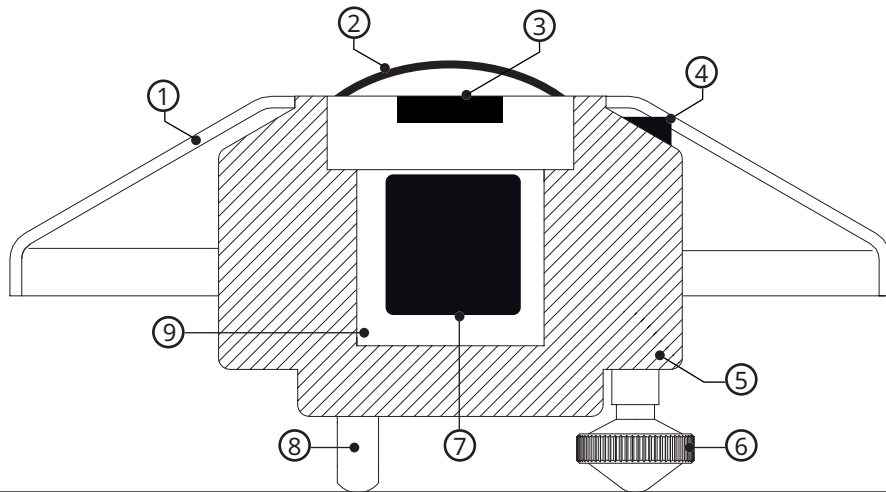

SGR4 Pyrgeometer

- | | | | |
|---|---------------------|---|-----------------|
| 1 | Sun shield | 6 | Adjustable feet |
| 2 | Silicon window | 7 | Smart interface |
| 3 | Thermopile detector | 8 | Fixed foot |
| 4 | Bubble level | 9 | Desiccant |
| 5 | Housing | | |

6 Transport, storage, and unpacking

6.1 Transport

- ▶ Transport the product always in its original packaging.
- ▶ Ensure that the product is not mechanically stressed during transport.

6.2 Storage

- ▶ Store within specified temperature ranges.
- ▶ Store in dry area.
- ▶ Store in original box where possible.

6.3 Unpacking

- ▶ Carefully remove the product from the packaging.
- ▶ Check that the delivery is complete and undamaged.
- ▶ If you find any damage or if the delivery is incomplete, then immediately contact your supplier or manufacturer.
- ▶ Keep the original packaging for any further transportation.

7 Installation

7.1 Mechanical installation

7.1.1 Preparatory work

- ▶ Check the desiccant of the CGR4 pyrometer and replace the desiccant if necessary.
- ▶ If using the digital output of the SGR4 pyrometer, set the Modbus® address before visiting the site. Otherwise a computer and RS-485 / USB converter is required during installation.

7.1.2 Required tools and aids

The following tools and aids are required:

- Allen key, 4 mm
- wrench, 8 mm

7.1.3 Installation for measuring long-wave downward radiation

7.1.3.1 Choosing a site

The majority of the IR radiation comes from the cold sky straight above the instrument. The closer to the horizon, the less contribution that part of the sky will give to the pyrometer signal, as the temperature of that part of the sky is almost equal to the instrument temperature. Even a tree near the instrument will not influence the signal much, as long as a cone of 90 degrees above the instrument is completely free.

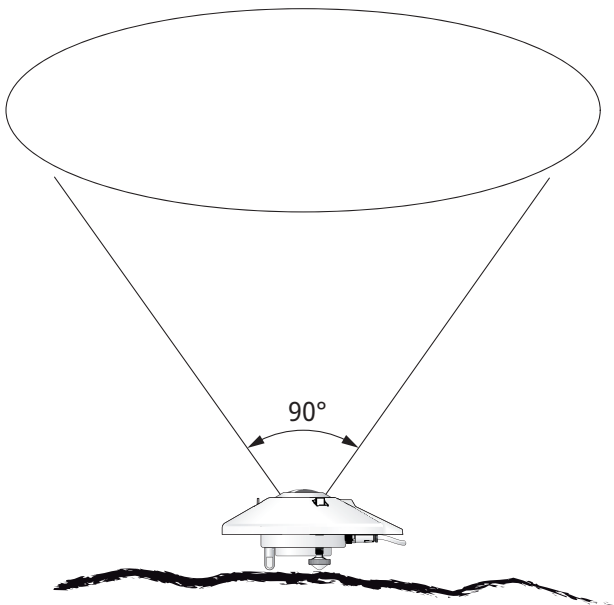

Minimum distance above the instrument

7.1.3.2 Mounting instrument

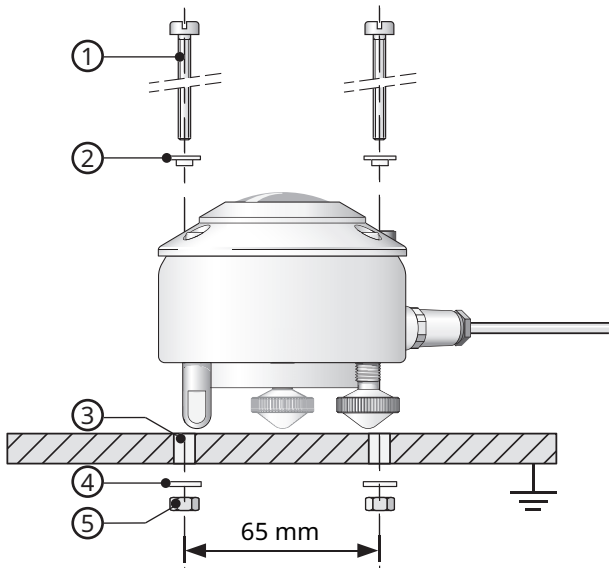

SGR4 Pyrgeometer

- | | | | |
|---|---------------------------|---|-----------------|
| 1 | 2x M5 x 80 mm screws | 4 | 2x flat washers |
| 2 | 2x nylon insulating rings | 5 | 2x nuts |
| 3 | 2x Ø 5.2 mm | | |

- ▶ To insulate the instrument against the temperature of the mounting device, place the instrument on the adjustable foot and the two leveling feet.
- ▶ Position the instrument in such a way that the nuts are located at a distance of 2 to 3 mm from the mounting device.
- ▶ Ensure that the instrument is grounded.
- ▶ Ensure that the instrument is not in the shade.
- ▶ When installed horizontally, point the cable connector towards the nearest pole to reduce the UV exposure on the cable.
- ▶ In order to align the instrument horizontally, rotate the leveling feet until at least half the spirit level bubble is in the inner ring.

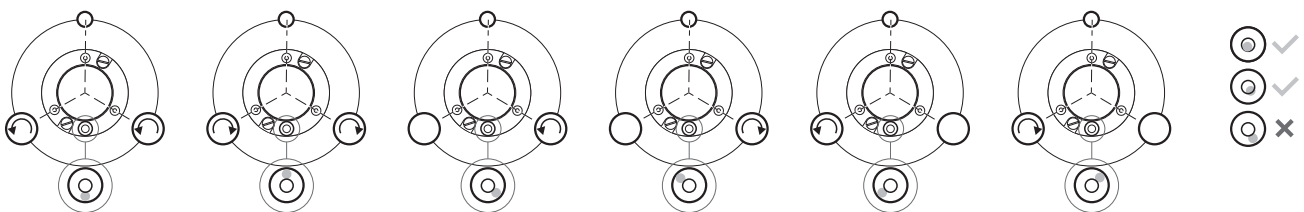

- ▶ Fix the instrument with the screws, ensure that the instrument retains the correct alignment.
- ▶ To prevent corrosion between the screws and the instrument housing, ensure that the nylon insulating rings are fixed.
- ▶ Insert the connector with the cable into the instrument's connection socket.
- ▶ Tighten the locking ring hand tight.
NOTICE! The seal may be damaged by overtightening!
- ▶ Fix the cable in such a way that the cable doesn't move or cast a shadow on the instrument.
- ▶ Fix the sun shield.

7.1.4 Installation for measuring upward long-wave radiation

In the inverted position the instrument measures radiation from the ground.

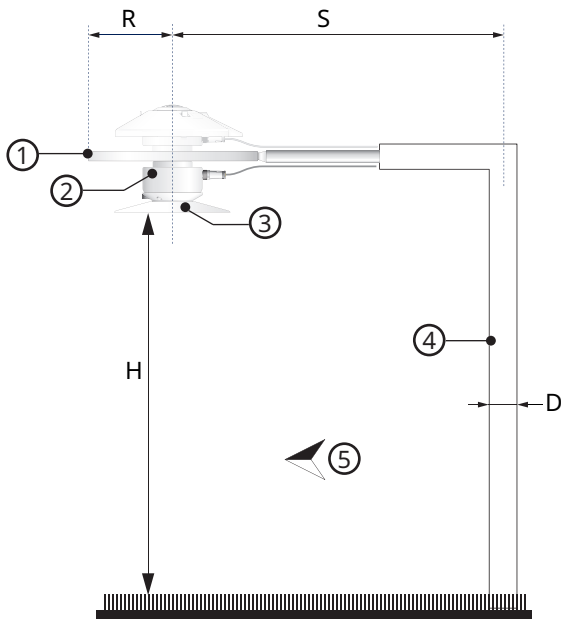

- | | | | |
|---|----------------|---|---------|
| 1 | Mounting plate | 4 | Mast |
| 2 | Pyrgeometer | 5 | Equator |
| 3 | Glare screen | | |

The mounting device must not significantly interfere the instrument's field of view. The mounting plate prevents excessive heating of the instrument body by solar radiation and keeps the glare screen free of precipitation.

7.1.5 Installation for shaded measuring downward long-wave radiation

As long as the instrument is suitably ventilated, the window heating effect from direct short-wave solar radiation is negligible.

For measuring atmospheric radiation with pyrgeometers it is desirable to shield the instrument from the direct short-wave solar radiation which may heat up the pyrgeometer window and cause significant thermal offsets. The direct solar radiation is intercepted by a small disk or sphere. The shadow of the disk must cover the pyrgeometer window completely. However, to follow the sun's apparent motion, a power-driven tracking device is necessary. This can be done using a Kipp & Zonen sun tracker, such as the model SOLYS2, designed to track the sun accurately under all weather conditions. Alternatively, a static shadow ring can be used to intercept the direct solar radiation; but it is less accurate and may require periodic manual adjustment. At times the shadow ring also intercepts a proportion of the diffuse sky radiation. Kipp & Zonen produces a universal shadow ring, model CM121, which is suitable for use at all latitudes.

In practice the SGR4 does not require shading from direct short-wave solar radiation because the window-heating effect, when suitably ventilated, is negligible due to the unique construction of the pyrgeometer.

A power-driven sun tracker or a static shadow ring can be used for this purpose. The sun tracker automatically tracks the sun's position accurately in all weather conditions. The shadow ring needs to be adjusted regularly. At times the shadow ring intercepts a significant proportion of the diffuse sky radiation.

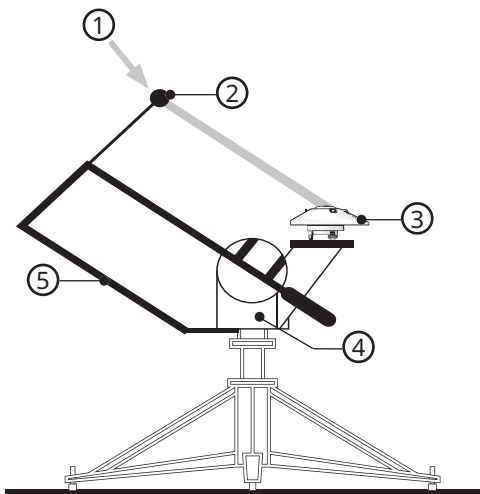

Sun tracker

- | | | | |
|---|-------------|---|------------------|
| 1 | Sun | 4 | Sun tracker |
| 2 | Shadow ball | 5 | Shading assembly |
| 3 | Pyrgometer | | |

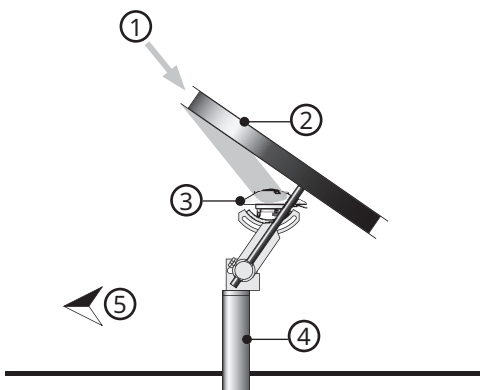

Shadow ring

- | | | | |
|---|-------------|---|------------------|
| 1 | Sun | 4 | Mounting bracket |
| 2 | Shadow ring | 5 | Equator |
| 3 | Pyrgometer | | |

7.1.6 Installation for measuring net long-wave radiation

A net pyrgometer measures both the downward atmospheric long-wave radiation and the upward long-wave radiation from the surface below. It can be configured from two pyrgometers and a suitable mounting plate. How to install the pyrgometers is described in the previous chapters.

When determining the net long-wave radiation, it is not necessary to record the pyrgometer housing temperatures. Assuming that the temperatures of the upper and lower housings are equal, it can be cancelled from the equation for net-radiation. However, if the upward and downward radiation components are to be measured separately it is necessary to record the individual housing temperatures to calculate the radiation values.

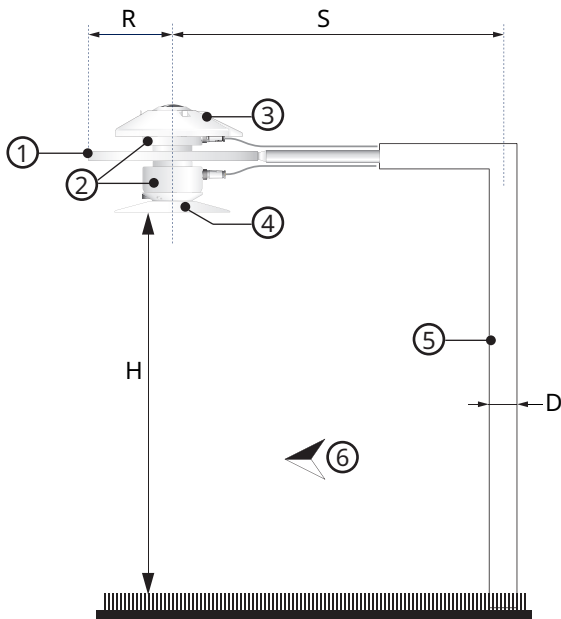

- | | | | |
|---|----------------|---|--------------|
| 1 | Mounting plate | 4 | Glare screen |
| 2 | Pyrometers | 5 | Mast |
| 3 | Sun shield | 6 | Equator |

- ▶ Read the previous chapters to learn how to install the instruments.
- ▶ Mount the instruments.

7.2 Electrical installation

7.2.1 Electrical connections of CGR pyrometers

- i** Long cables may be used if the cable resistance is less than 0.1 % of the impedance of the readout equipment for the analog outputs.

The CGR pyrometers can be supplied with a waterproof plug pre-wired to 10 m of high quality yellow cable with 8 wires and a shield covered with a black sleeve. Longer cables are available as options. The number of plug pins and cable leads depends upon the type of temperature sensor that is fitted. The color code of the wires and the connector pin numbers are shown below and on the instruction sheet.

The impedance of the readout equipment loads the temperature compensation circuit and the thermopile. It can increase the temperature dependency of the pyrometer. The sensitivity is affected more than 0.1% when the load resistance is less than 100 k Ω . For this reason we recommend the use of readout equipment with an input impedance of 1 M Ω or more. The solar integrators, data loggers and chart recorders from Kipp & Zonen meet these requirements.

It is evident that the use of attenuator circuits to modify the calibration factor is not recommended because the temperature response will also be affected.

A high input bias current at the readout equipment can produce several micro-Volts across the impedance of the pyrometer and cable. The zero offset can be verified by replacing the pyrometer impedance at the readout equipment input terminals with a resistor.

The pyrgometer can also be connected to a computer or data acquisition system. A low voltage analogue input must be available. The resolution of the Analogue-to-Digital Converter (ADC) must allow a system sensitivity of about 1 bit per W/m². More resolution is not necessary during outdoor measurements, because even the best pyrgometer (the CGR 4) exhibits offsets greater than 2 W/m² due to lack of thermal equilibrium.

7.2.1.1 Radiometer connection

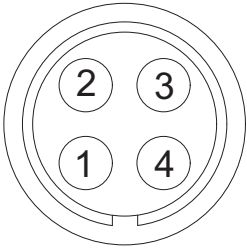

4-pin unit plug

Pin assignment

Wire Number	Color	Function	Connect to
1	Red	+	+ (Hi)
2	Blue	-	- (Lo)
Shield		Housing	Ground

The temperature connector carries the signals for the PT-100 (4 wires) and Thermistor (2 wires).

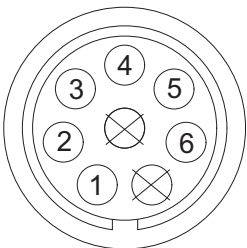

6-pin temperature plug

Pin assignment

Wire Number	Color	Assignment
4	Yellow	Thermistor standard
3	Green	
4	Yellow	Combined Pt-100 standard
6	Brown	
3	Green	Combined Pt-100 standard
5	Grey	

7.2.2 Electrical connections of SGR pyrgeometers

The SGR pyrgeometers can be supplied with a waterproof plug pre-wired to 10 m of high quality yellow cable with 8 wires and a shield covered with a black sleeve. Longer cables are available as options. The colour code of the wires and the connector pin numbers are shown in chapter Connecting to computer [► 21] and on the instruction sheet.

7.2.2.1 Power connection

The minimum power supply voltage for the instrument is 5 V DC. 5-volt-power can only be used with a short cable, maximum 10 m. To ensure reliable performance, a voltage of 12 V DC is recommended. For the output of the power supply, it is recommended to protect it with a fast blowing fuse of maximum 250 mA rating.

7.2.2.2 Power consumption

Typical power consumption SGR-V for maximum output (1 V)

Voltage (V DC)	Current (mA)	Power (mW)
5	10.0	50
12	4.5	55
24	2.5	60

- Maximum power consumption 65 mW at the highest input voltage.
- Maximum input current 12.5 mA at the lowest input voltage.
- Maximum inrush current 200 mA.

Typical power consumption SGR-A for max output (20 mA)

Voltage (V DC)	Current (mA with 100 Ω load resistor)	Power (mW)
5	28	77
12	24	83
24	6	100

The above mW values represent the dissipation within the SGR-A. For the total power the energy in the load resistor has to be added.

For supply voltages below 12 Volts or above 20 Volts use a load resistor of less than 500 Ω to keep the power consumption as low as possible.

7.2.2.3 Analog voltage output

The SGR-V (voltage output versions) have been factory set such that an output of 0 Volts represents 0 W/m² (this will never be reached in practice), and the full-scale output of 1 Volt represents 1000 W/m². The voltage output range in W/m² can be changed with the supplied PC software. The maximum recommended irradiance for all SGR pyrgeometers is 1000 W/m².

The default setting 0 to 1 Volt represents 0 to 1000 W/m².

The downward atmospheric long-wave radiation ($L_{d\downarrow}$) for the default setting can be simply calculated as shown below:

$$L_{d\downarrow} = (V \times 000)$$

$$L_{d\downarrow} = \text{Downward atmospheric long-wave radiation [W/m}^2\text{]}$$

$$V = \text{Output of radiometer [Volt]}$$

If the pyrgeometer is used in atmospheric conditions, it is advised to keep the range as factory set.

7.2.2.4 Analog current output

The SGR-A (current output versions) have been factory set such that an output of 4 mA represents 0 W/m² and the full-scale output of 20 mA represents 1000 W/m². The current output range in W/m² can be changed with the supplied PC software. The maximum recommended irradiance for the SGR pyrgeometer is 1000 W/m².

Negative inputs will make the output go below 4 mA and no zero offset is needed. For the default setting of 4 to 20 mA representing 0 to 1000 W/m².

The irradiance value ($L_{d\downarrow}$) for the default setting can be calculated as shown below:

$$L_{d\downarrow} = (\text{mA} - 4) \times (1000/16)$$

$$L_{d\downarrow} = \text{Downward atmospheric long-wave radiation [W/m}^2\text{]}$$

$$\text{mA} = \text{Output of radiometer [mA]}$$

7.2.2.5 Connecting to computer

NOTICE

Damage due to lack of insulation!

The power supply units of portable computers such as laptops can generate large voltage peaks. This may cause damage to the instrument's digital interface.

- ▶ Ensure that the converter has galvanic isolation between the inputs and outputs.

The instrument must be connected to a computer via an RS-485 converter with a USB port.

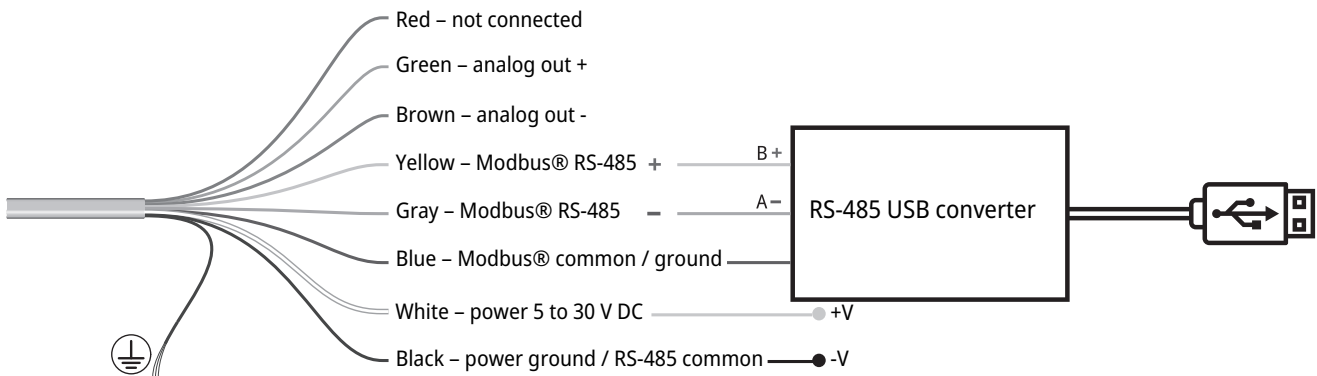

Connection to RS-485 converter

- ▶ Ensure that the power supply is switched off.
- ▶ Connect the white wire to the black wire on the power supply unit.
- ▶ Connect the yellow, gray and blue wires to the RS-485 converter.
- ▶ Isolate and seal any other wires when they are not in use.
- ▶ Align the indentation on the plug with the indentation on the instrument's connection socket.
- ▶ Connect the plug to the instrument.
- ▶ Turn the locking ring clockwise and tighten it hand tight to secure the connector.
NOTICE! The seal may be damaged by overtightening!
- ▶ Switch on the power supply.
- ▶ Switch on the computer.

7.2.3 Grounding instrument

The shield of the cable is connected to the aluminum housing of the instrument through the plug body.

- ▶ Secure the instrument with its leveling screws on a metal support with a good connection to ground, e.g. by using a lightning conductor.
- ▶ Do not connect the cable shield at the readout end.
- ▶ If there is no good ground connection at the instrument, connect the ground at the readout equipment.

8 Commissioning

8.1 Instrument set-up

The Smart Explorer software allows to configure a smart sensor and to collect real-time data.

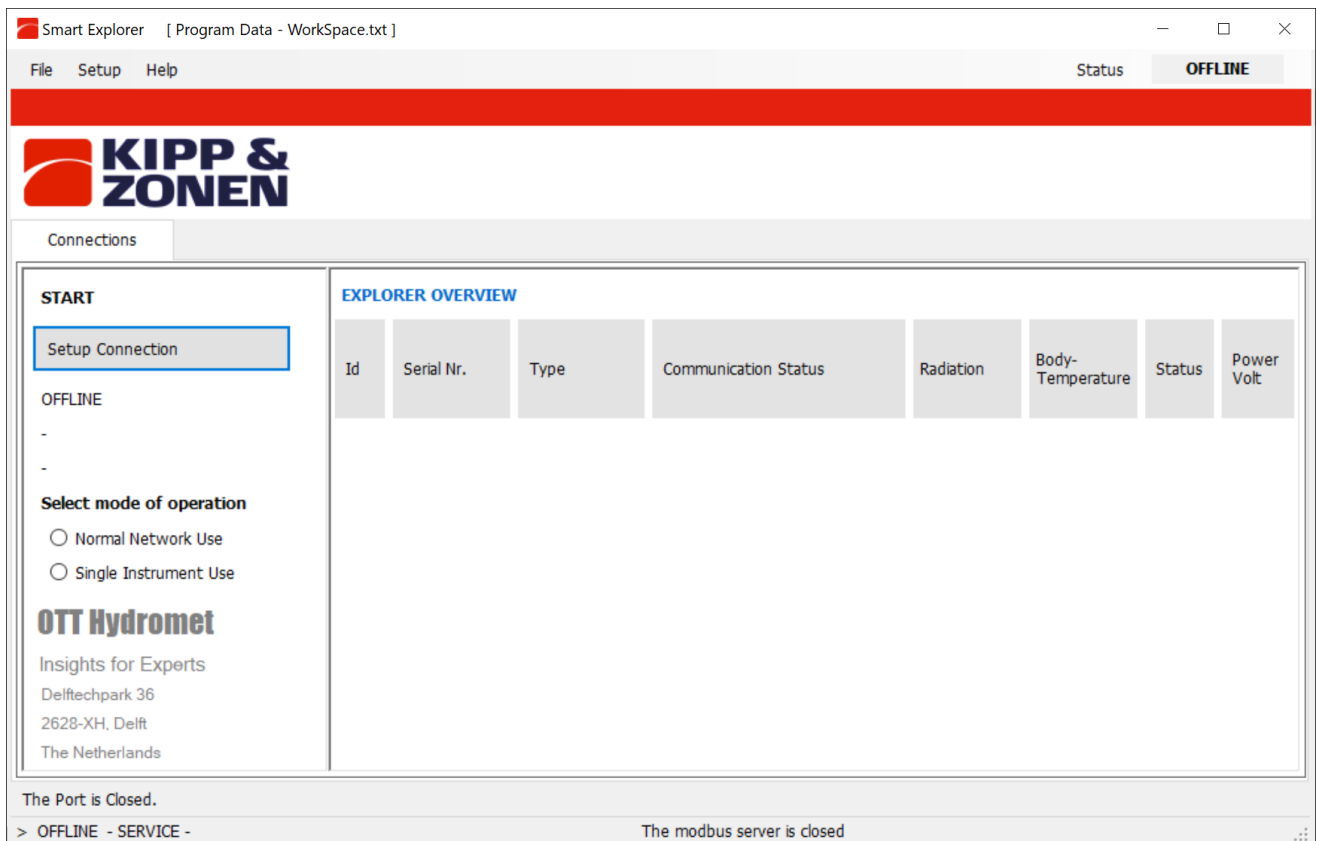

The factory default communication parameters are as follows:

- Modbus® baud rate: 19200
- Parity: even
- Data bits: 8
- Stop bits: 1
- Address: 1

- ▶ If using the software on-site, ensure that the software is already installed on the laptop.
- ▶ For detailed information about setup, monitoring, and data logging, see the Smart Explore software manual.
- ▶ Download the Smart Explorer software and the manual at the following address: www.otthydromet.com

9 Maintenance

9.1 Maintenance schedule

The frequency of cleaning is dependent upon the local weather and environmental conditions. Ideally, the window of the instrument should be cleaned at regular intervals. The frequency of cleaning can be reduced by the use of a ventilation unit, with the heaters switched on when necessary.

The following maintenance intervals are recommended:

Interval	Activity	Performed by
Twice a week	<ul style="list-style-type: none">▶ Clean the window using a dry and lint-free cloth.▶ For persistent soiling, use additional distilled water. If the soiling is severe, pure alcohol can be used.▶ Ensure that no streaks or deposits are left on the dome.	Operator
Monthly	<ul style="list-style-type: none">▶ Check that the instrument is level. Adjust the instrument if required.▶ Check that the sun shield is fixed tightly.▶ For CGR4, check the desiccant in the drying cartridge and replace it when the color changes from orange to clear (transparent).	Operator
Annually	<ul style="list-style-type: none">▶ Check all electrical connections: Unscrew the plugs, clean the plugs if necessary and reconnect.▶ Check all cables for damage.▶ Check fastenings and basic supports.▶ Clean the sun shield if dirty.	Operator
2 years	<ul style="list-style-type: none">▶ Check sensitivity or have a recalibration performed.	OTT HydroMet
10 years	<ul style="list-style-type: none">▶ Replace the desiccant in the SGR4 pyrgeometer.	OTT HydroMet

9.2 Replacing desiccant

The SGR4 pyrgeometer has an internal desiccant that need replacement after 10 years. This is done with every factory re-calibration.

The desiccant of the CGR4 pyrgeometer can be replaced with the following steps:

- ▶ Unscrew the drying cartridge from the instrument housing. If the cartridge is tight, then use a 16 mm or 5/8" open-ended wrench.
- ▶ Remove the cap from the end of the cartridge and dispose the used desiccant.
- ▶ Refill the cartridge with fresh desiccant.
- ▶ Place the cap on the cartridge.
- ▶ Ensure that the o-ring seal and its seat in the housing are clean.
- ▶ Grease the seal with Vaseline if it is dry.
- ▶ Screw in the cartridge hand tight in the instrument housing.
- ▶ Check that the instrument is level and adjust if necessary.
- ▶ Check that the sun shield is firmly clipped on.

10 Troubleshooting

10.1 Error elimination

Error	Possible cause	Corrective action
Output signal not available or incorrect	Instrument does not work properly	<ul style="list-style-type: none">▶ Check that the cables are correctly connected to the readout equipment.▶ Check the window for contamination. Carry out maintenance work as required.▶ Check that the leveling is correct.▶ Report any malfunctions or damage to the representative of OTT HydroMet.▶ For SGR4 pyrheliometer: Check the last calibration date to see if re-calibration, or desiccant replacement is required.▶ For CGR4 pyrheliometer:<ul style="list-style-type: none">– Check the impedance. See specifications for expected values.– Check the data logger or readout offset by connecting a dummy load (100 Ohm resistor). This should give a "zero" reading.– If water is deposited on the inside of the window, change the desiccant.

11 Repair

11.1 Customer support

- ▶ Have repairs carried out by OTT HydroMet service personnel.
- ▶ Only carry out repairs yourself, if you have first consulted OTT HydroMet.
- ▶ Contact your local representative: www.otthydromet.com/en/contact-us
- ▶ Include the following information:
 - instrument model
 - instrument serial number
 - details of the fault or problem
 - examples of data files
 - readout device or data acquisition system
 - interfaces and power supplies
 - history of any previous repairs or modifications
 - pictures of the installation
 - overview of the local environment conditions

12 Notes on disposing of old devices

Member States of the European Union

In accordance with the German Electrical and Electronic Equipment Act (ElektroG; national implementation of EU Directive 2012/19/EU), OTT HydroMet takes back old devices in the Member States of the European Union and disposes of them in the proper manner. The devices that this concerns are labeled with the following symbol:



- ▶ For further information on the take-back procedure contact OTT HydroMet:

OTT HydroMet B.V.

Service & Technical Support

Delftechpark 36

2628 XH Delft

The Netherlands

phone: +31 15 2755 210

email: solar-info@otthydromet.com

All other countries

- ▶ Dispose of the product in the proper manner following decommissioning.
- ▶ Observe the country-specific regulations on disposing of electronic equipment.
- ▶ Do NOT dispose of the product in household waste.

13 Technical data

13.1 Optical and electrical data

Specification	CGR4	SGR4
Analog output , V-version	–	0 to 1 V
Analog output range, V-version	–	0 to 1000 W/m ²
Analog output , A-version	–	4 to 20 mA
Analog output range, A-version (Longwave down radiation)	–	0 to 1000 W/m ²
Serial output	–	RS-485 Modbus®
Serial output range (Longwave down radiation)	–	0 to 1000 W/m ²
Impedance	40 to 200 Ω	–
Response time (63 %)	< 6 s	< 6 s
Response time (95 %)	< 18 s	< 18 s
Spectral range (50 % points)	4500 to 42 000 nm	4500 to 42 000 nm
Zero offset (unventilated): temperature change (5 K/h)	< 2 W/m ²	< 2 W/m ²
Non-stability (change/year)	< 1 %	< 1 %
Non-linearity (-250 to 250 W/m ²)	< 1 %	< 1 %
Window heating offset (with 1000 W/m ² direct solar radiation)	< 4 W/m ²	< 4 W/m ²
Temperature response	< 5 % (-40 °C to -20 °C) < 1 % (-20 °C to +50 °C) < 10 % (+50 °C to +80 °C)	< 1 % (-20 °C to +50 °C) < 1 % (-40 °C to +70 °C)
Spectral selectivity (8 to 14 μm)	< 5 %	< 5 %
Tilt response (0° to 90° at ±250 W/m ²)	< 1 %	< 1 %
Field of view	180°	180°
Accuracy of bubble level	< 0.1°	< 0.1°
Power consumption (at 12 V DC)	–	V-version: 55 mW A-version: 100 mW
Software, Windows™	–	Smart Explorer Software, for configuration, test and data logging
Supply voltage	–	5 to 30 V DC
Detector type	Thermopile	Thermopile
Operating temperature range	-40 °C to +80 °C	-40 °C to +80 °C
Storage temperature range	-40 °C to +80 °C	-40 °C to +80 °C
Humidity range (non-condensing)	0 to 100 %	0 to 100 %
Protection rating	IP67	IP67

13.2 Dimensions and weight

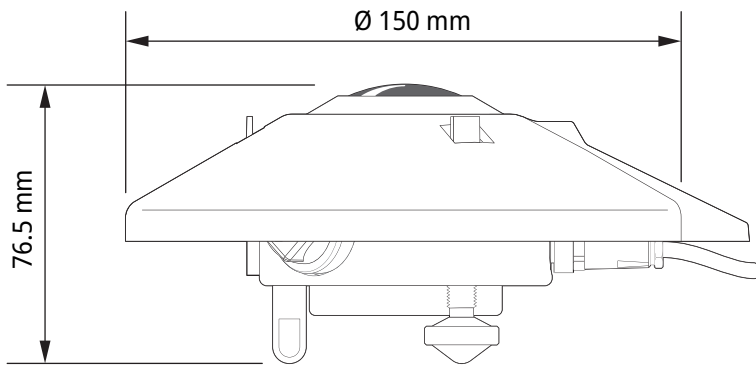

CGR4, 600 g

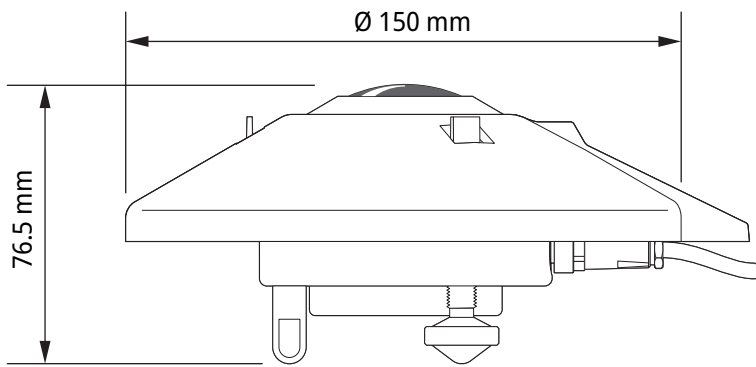

SGR4, 600 g



Contact Information

