

# Instruction Manual

---

CVF4 Ventilation Unit

Valid for part number 0378910-xxx up to serial number CVF4193799



## Important user information

Dear customer, thank you for purchasing a Kipp & Zonen instrument. It is essential that you read this manual completely for a full understanding of the proper and safe installation, use, maintenance and operation of your new CVF4 Ventilation Unit .

We understand that no instruction manual is perfect, so should you have any comments regarding this manual we will be pleased to receive them at:

Kipp & Zonen B.V.  
Delftechpark 36, 2628 XH Delft, - or  
P.O . Box 507, 2600 AM Delft,  
The Netherlands

+31 15 2755 210  
support@ kippzonen.com  
www.kippzonen.com

### Warranty and liability

Kipp & Zonen guarantees that the product delivered has been thoroughly tested to ensure that it meets its published specifications. The warranty included in the conditions of delivery is valid only if the product has been installed and used according to the instructions supplied by Kipp & Zonen.

Kipp & Zonen shall in no event be liable for incidental or consequential damages, including without limitation, lost profits, loss of income, loss of business opportunities, loss of use and other related exposures, however incurred, rising from the faulty and incorrect use of the product.

Modifications made by the user may affect the instrument performance, void the warranty, or affect the validity of the CE declaration or other approvals and compliances to applicable International Standards.

Copyright © 2016 Kipp & Zonen B.V.

All rights are reserved. No part of this publication may be reproduced, stored in a retrieval system or transmitted, in any form or by any means, without authorisation by Kipp & Zonen.

Kipp & Zonen reserves the right to make changes to this manual, brochures, specifications and other product documentation without prior notice.

Manual document number:V1610

Publication date: 1<sup>st</sup> October 2016





**KIPP &  
ZONEN**  
SINCE 1830

## Declaration of Conformity



Kipp & Zonen B.V.  
Delftechpark 36, 2628 XH Delft  
P.O. Box 507, 2600 AM Delft  
The Netherlands

declares under our sole responsibility that the product

CVF4 Ventilation Unit

to which this declaration relates, is in conformity with European Harmonised Standards  
as published in the Official Journal of the EC, based on the following standard

[EMC - Emissions] EN 61326-2-1:2013 and EN 61326-2-3:2013

[EMC - Immunity] EN 61326-2-1:2013 and EN 61326-2-3:2013

following the provisions  
EMC-directive 2014/30/EC

also, this device complies to  
[EMC - FCC] Title 47CFR part 15

Delft, 20 April 2016

E. van Houten - CFO  
Kipp & Zonen B.V.



# Table of Contents

Important User Information	3
Declaration of Conformity	5
1 Introduction	9
1.1 CVF4 top side	10
1.2 CVF4 bottom side	10
2 Installation	11
2.1 Included with the product	11
2.2 Tools required	11
2.3 Preparation	11
2.4 Installation procedure	12
2.5 Electrical connections	14
3 Accessories	15
3.1 Spare CVF4 filters	15
3.2 Power supply	15
3.2.1 CVP1	15
3.2.2 CVP2	15
3.3 CMF4 Mounting Fixture	16
3.4 CMB1 Mounting Bracket	16
3.5 Adapter for use of the CVF4 in the CM121C shadow ring	17
4 Maintenance	19
5 Specification	21
5.1 Optical and electrical	21
5.2 Dimensions and weight	21
6 Trouble shooting	23
7 Customer support	25



## Using this table

Click on any item in the table of contents to be taken directly to the relevant page.

Click on the bottom of any page to be taken back to the table of contents.



# 1. Introduction

This manual will show you how to install, use and maintain the CVF4 Ventilation Unit. The CVF4 is meant for ventilating solar radiation sensors with the purpose to keep the mounted radiometer window or dome clean from dew, precipitation and pollution. It can be used outdoors under all-weather conditions. The CVF4 has a built in heater to keep the air just above ambient temperature.

Both the World Meteorological Organisation (WMO) and the Baseline Surface Radiation Network (BSRN) guidelines advise using a ventilator to optimise the performance of radiometers in general.

The use of the CVF4 will:

- Increases the maintenance interval.
- Increase the accuracy of the measured data (cleaner dome / window)
- Reduce the zero offset of the radiometer.

The CVF4 is meant for all CM, CMP, SMP, CG, CGR and CUV radiometers. However with the CMP3 and SMP3 and CGR3 the ventilation effect will be less due to the larger opening around the dome. The CVF4 is meant to run continuously. The heater can either be switched on permanently for cold regions or be switched by a data logger or clock to remove dew in the morning and be switched off afterwards. In that case the heater is operated from a 2 hours before sunrise to an hour after sunrise. This saves power in situations where power is limited such as PV operated sites.

This manual, together with the instruction sheet, give information related to installation, maintenance, product specifications and trouble shooting of the CVF4.

If any questions should remain, please feel free to contact your Kipp & Zonen dealer or e-mail: [info@kipppzonen.com](mailto:info@kipppzonen.com) .

For information about other Kipp & Zonen products or to check for any update of this manual, go to [www.kipppzonen.com](http://www.kipppzonen.com)

### 1.1 CVF4 top side

- ① Ventilator
- ② Heater
- ③ Mounting holes CMP3, SMP3 and CGR3
- ④ Mounting holes all other instruments
- ⑤ Connector
- ⑥ Cover nut
- ⑦ Slit for radiometer

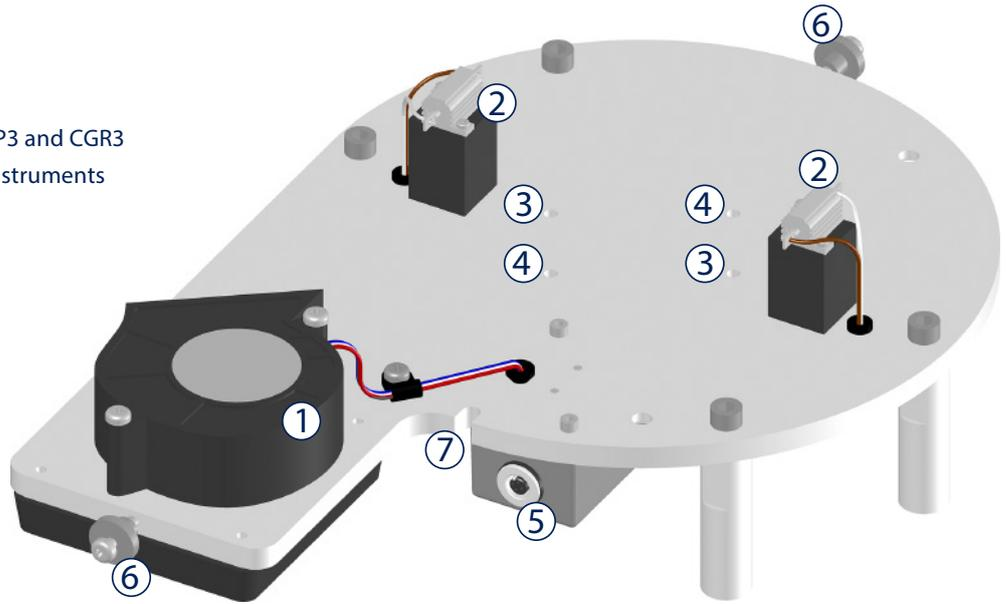

### 1.2 CVF4 bottom side

- ① Filter cover
- ② Connector box
- ③ Mounting feet for SOLYS2 / Feet for stabilisation
- ④ Feet for stabilisation / Mounting feet for 2AP
- ⑤ Mounting holes for mounting feet on CM121C shadow ring adapter
- ⑥ Cover nut

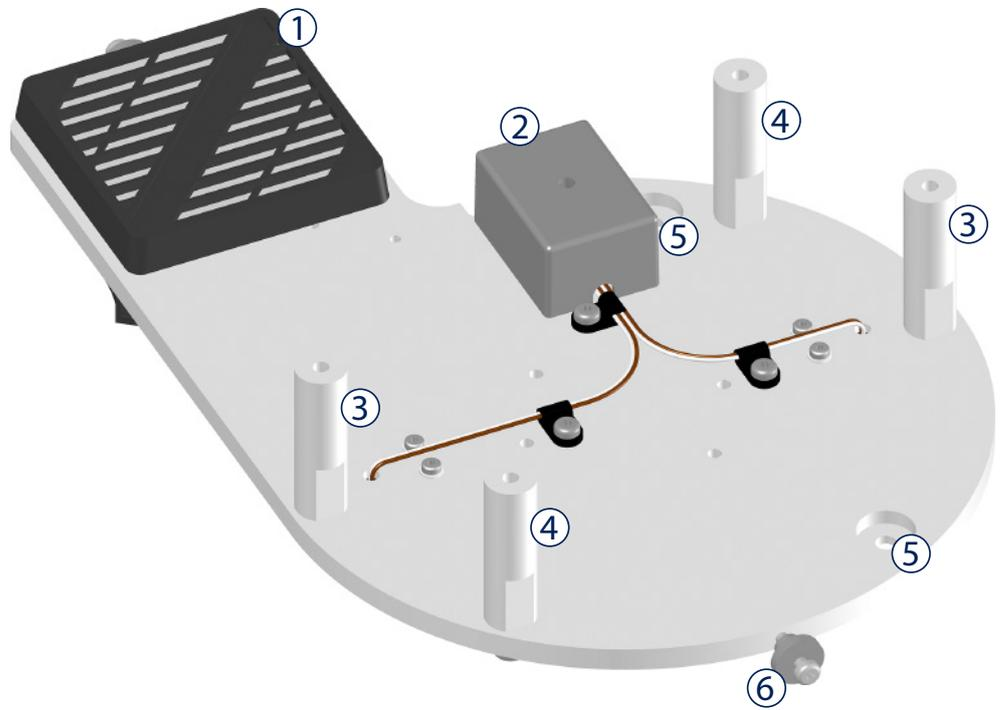

## 2. Installation

The CVF4 consists of:

- Base plate with ventilator, heater and connector
- Replaceable filter plus cover
- Top cover

### 2.1 Included with the product

The following items are included with the CVF4 ventilation unit:

- ① Ventilation Unit
- ② (Optional) 8-wire cable with connector or 8 pins connector only for customer cable
- ③ Fixing kit with screws, washers and Allan key
- ④ Instruction sheet
- ⑤ Pack of 5 spare ventilation fan inlet filters

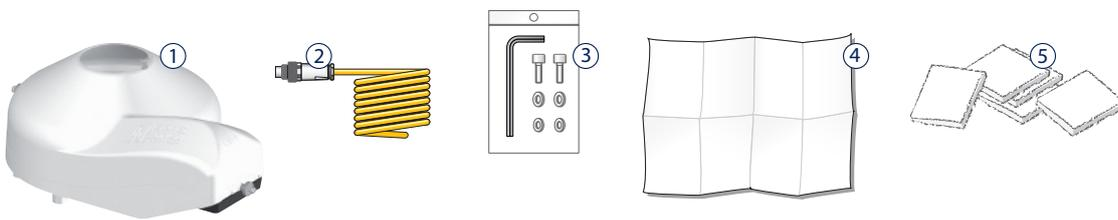

For optional accessories see chapter 3.

### 2.2 Tools required

If the CVF4 is mounted with the supplied screws only the supplied Allan key is required. Make sure there is space to fasten the screw under the bottom of the plate. To fasten the radiometers other Allan keys or screwdrivers may be necessary.

### 2.3 Preparation

Like for any radiometer with 360° field of view, make sure there are no obstructions that are higher than ten times their distance when selecting a location for the CVF4.

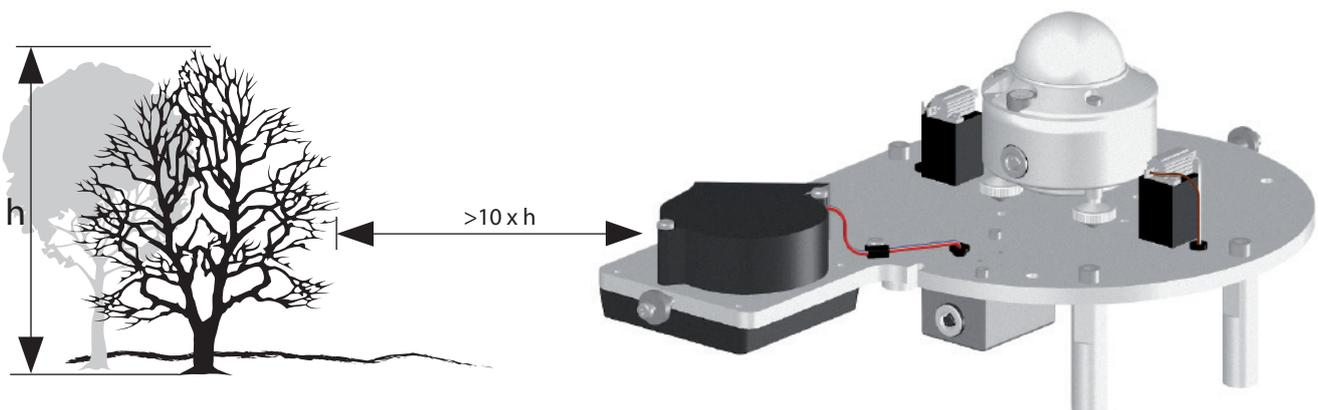

## 2.4 Installation procedure

First the CVF4 is screwed flat on its mounting plate. In case the CVF4 is mounted on a solar tracker, the tracker has to be levelled first.

On our sun trackers the CVF4 is positioned such that the fan sticks out over the edge of the plate. This ensures the air inlet is never blocked (see picture of the CVF4 on the SOLYS2 Sun Tracker on the next page). The locations of the CVF4 mounting holes on the SOLYS2 top mounting plate are shown below.

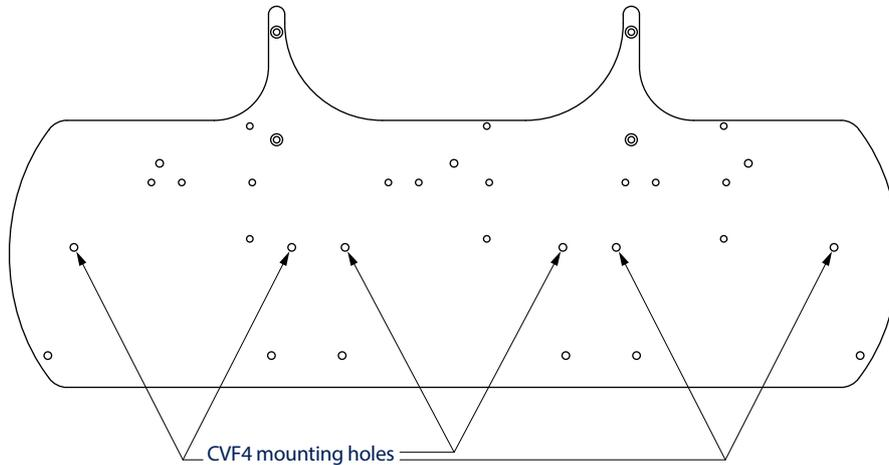

When using your own mounting plate, make sure the CVF4 is mounted in the same way with the fan sticking out. The CVF4 mounting holes size and distances are indicated in the drawing below.

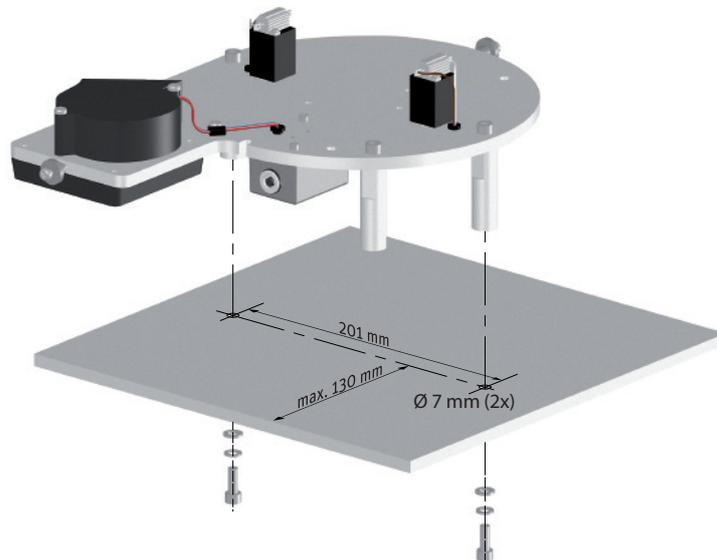

The CVF4 is mounted with the supplied 4 washers and 2 screws through mounting plates from 4 to 8 mm thick. The other 2 feet are for stability but do not need screws.

Then the radiometer is mounted in the CVF4 and levelled with its own levelling feet. Afterwards the radiometer mounting screws and shoulder washers are fitted (not secured yet).

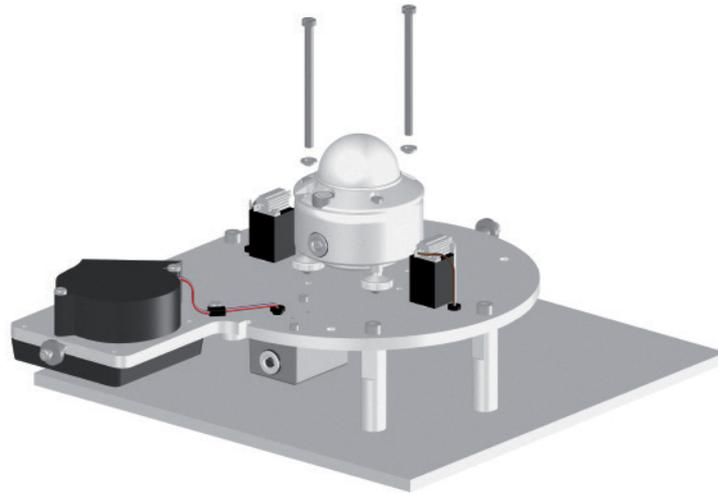

In case the CVF4 is mounted on a solar tracker, finish the alignment of the tracker first before securing the radiometer screws because tracker (and radiometer) levelling might need re-adjustment.

After all mounting screws have been secured the cables of the CVF4 and the radiometer can be connected. The radiometer cable goes (down) through the slit in the CVF4 base plate.

Finally the CVF4 cover can be put on and the two cover nuts can be fastened.

Make sure the cover is horizontal (check equal space around the radiometer dome) and the two cover nuts are fastened hand tight.

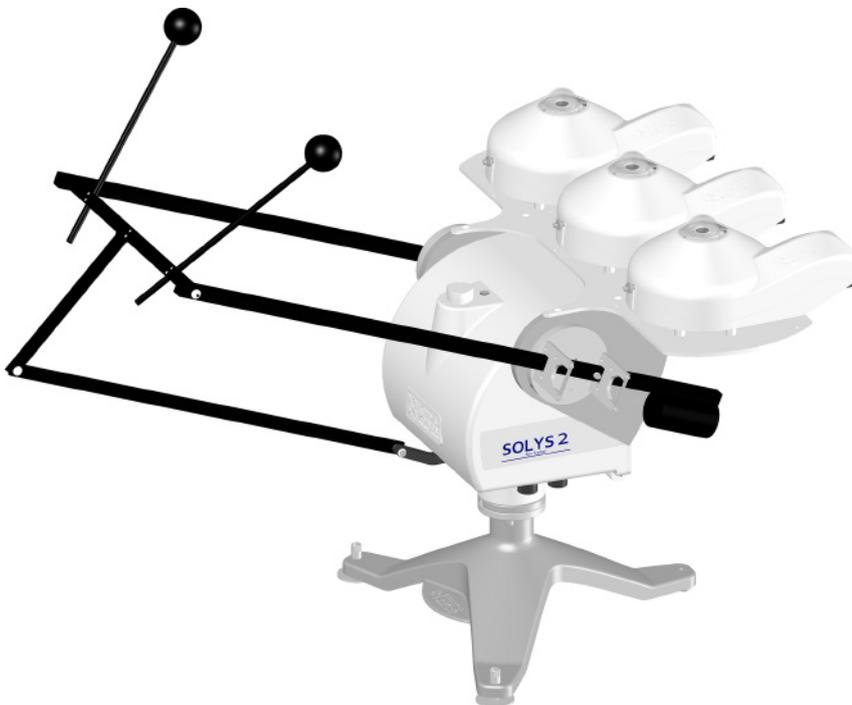

SOLYS2 with top mounting plate and 3 x CVF4



SOLYS2 with small top mounting plate with CVF4

## 2.5 Electrical connections

Ventilation Unit Connection			
Wire	Function	Connect with	
4	Yellow	Ventilator +	+ 12VDC @ 0.4 A (2)
6	Brown	Ventilator -	Ground (2)
3	Green	Tacho +	Tacho output +
5	Grey	Tacho -	Tacho ground
7	White	Heater +	+ 12VDC @ 0.5 A (1)
8	Black	Heater +	+ 12VDC (1)
1	Red	Heater -	Ground (1)
2	Blue	Heater -	Ground (1)
Shield	Housing	Ground *	
* Connect to ground if radiometer not grounded			
Ground 1/2 and +12 VDC 1/2 are separated but may be connected			

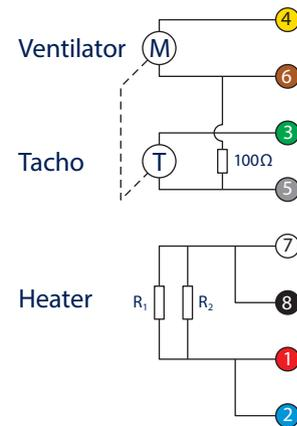

The CVF4 has an optional 8-wire cable for connecting the 12 VDC to the ventilator and heater. The ground is common for the ventilator, heater and the tacho output.

The tacho output provides a 5 Volt signal that gives two pulses per revolution. It can be connected to a data logger to (remotely) check proper operation of the CVF4. Ventilator and heater ground are separated but may be connected. Ventilator and tacho ground are connected via a 100 Ω resistor.

The nominal speed is 4400 rpm, resulting in 8800 pulses per minute which equals 146 Hz on the tacho output.

Changes often indicate pollution of the filter (higher frequency), or mechanical problems with ventilator (lower frequency).

If sufficient power is available it is advised to use the heater in combination with the ventilator even in warm climates. The heater will prevent deposition of dew in the morning.

### 3. Accessories

#### 3.1 Spare CVF4 filters

Article number 2682047

Set of 5 spare ventilation fan inlet filters.

#### 3.2 Power supply

Two optional 12 VDC power supplies are available for outdoor (CVP1) and indoor (CVP2) use.

##### 3.2.1 CVP1

Article number 0357700



The CVP1 is a waterproof (IP 65) power supply for outdoor use with 12 VDC @ 3.5 A output. The input is wide range 100 to 240 VAC, 50 or 60 Hz.

##### 3.2.2 CVP2

Article number 0349401



This is a 12 VDC, 2.5 A power supply for indoor use with a wide VAC input range of 110 to 230 VAC, 50 or 60 Hz. It comes with universal mains power plugs for Europe, UK, USA and Australia.

The DC output cable from the power supply unit are stripped and tinned wires, marked with a red sleeve on the + wire.

### 3.3 CMF4 Mounting Fixture

Article number 0362703

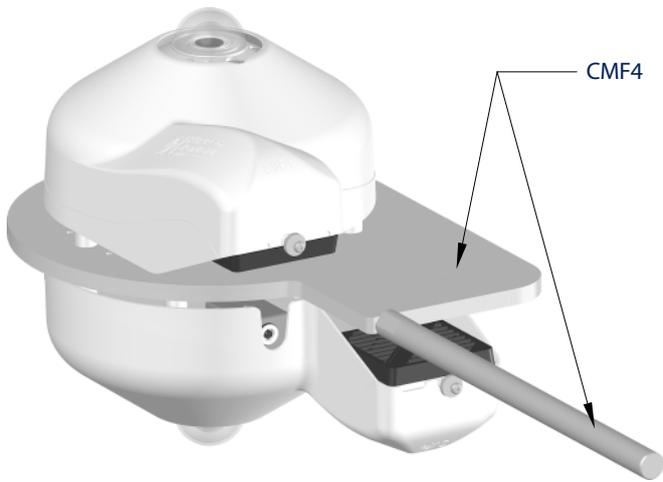

The CMF4 consists of a mounting plate plus rod. It can be used for one CVF4, looking up or 2 CVF4's where one is looking down. This allows for highly accurate albedo or net-radiation measurements with 2 ventilated radiometers.

### 3.4 CMB1 Mounting Bracket

Article number 0369701



To mount the CMF4 to a mast or wall the CMB1 mounting bracket can be used.

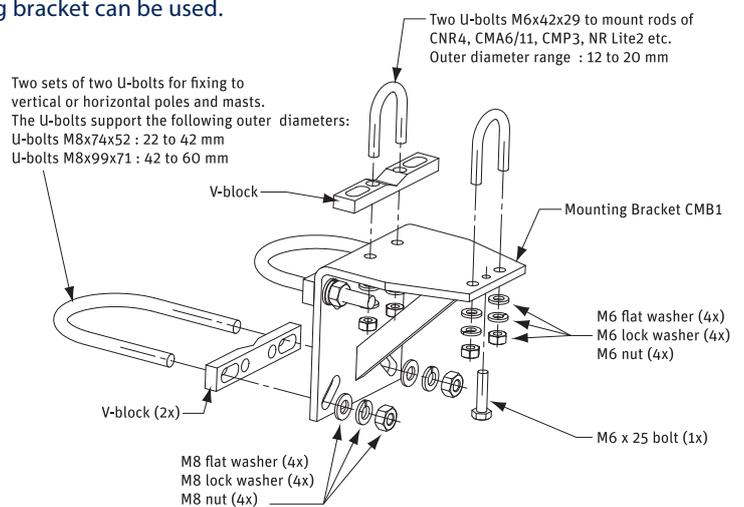

### 3.5 Adapter for use of the CVF4 in the CM121C shadow ring

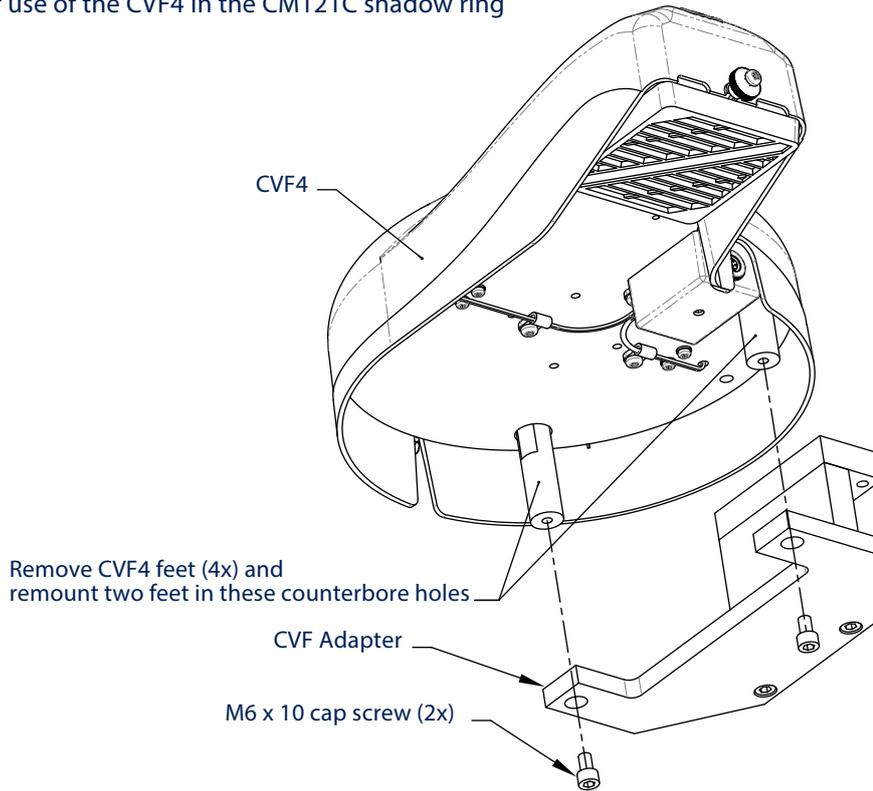

Relocation of 2 of the CVF4 mounting feet to fit it on the CM121C shadow ring



The blue adapter part is included with the CM121C.



CM121B (Article number 0346900) is not supplied with, nor aligned for the CVF4 adapter (Article number 0346700)  
CM121C (Article number 0346901) is aligned for and supplied with the CVF4 adapter



## 4. Maintenance

Regular inspection of the CVF4 is advised. Depending on the location (air pollution) this can be monthly or yearly. When on site for inspection of other instruments it is advised to check the CVF4 filter.

At the same time radiometer levelling and desiccant can be checked. For access to the desiccant the 2 mounting nuts have to be loosened and the top cover taken off.

When replacing the cover, make sure it is placed correctly. This can best be done by checking the opening around the radiometer, this should be evenly spaced.

Tip: When the tacho output is logged with the radiometer data, the performance of the ventilator can be remotely checked.

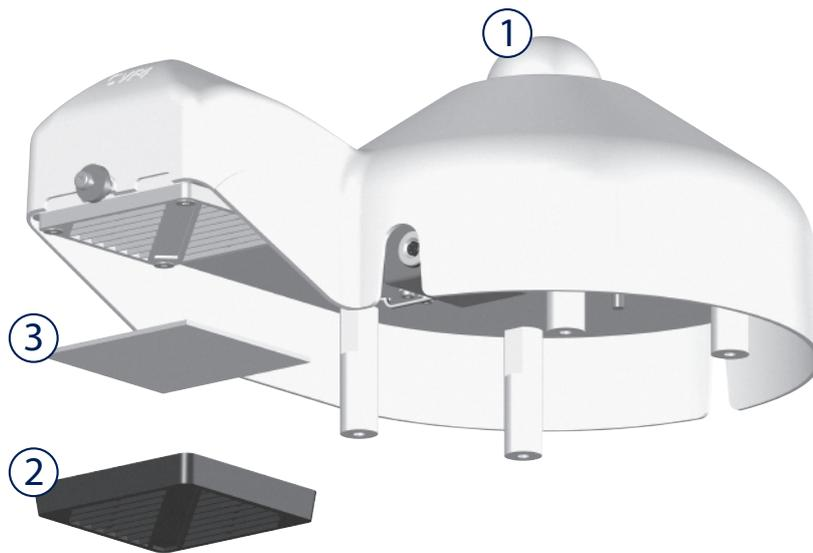

- ① Refer to radiometer instruction sheet for maintenance instructions.
- ② Regularly inspect the fan inlet by unclipping the cover.  
For optimal air flow, make sure the diagonal line on the cover is in line with the ventilator part (see above drawing).  
The filter cover clicks back on the ventilator.
- ③ Clean or replace filter every 6 months.  
The interval strongly depends on the location and pollution of the air. Discolouration or pollution of the plastic cover will not affect the proper operation of the radiometer. (the radiometer can not 'see' the CVF4 cover). Cleaning of the cover can be done with water and a brush or cloth.



## 5. Specification

Kipp & Zonen reserves the right to make changes to specifications and other product documentation without prior notice.

### 5.1 Optical and electrical

Specifications	
Compatible instruments	CMP6, CMP10, CMP11, SMP11, CMP21, CMP22, CGR4, CUV 5 CMP3, SMP3 and CGR3 with reduced specifications Older type single radiometers: CM, CG and CUV will also fit
Compliance with standards	ISO/TR 9901, BSRN operations manual
Power consumption ventilator (unheated)	5 W continuously at 12 VDC
Power consumption heater (selectable)	5.5 W at 12 VDC
Operational voltage range	8 to 13.5 V
Operational temperature range	-40 °C to +70 °C
Storage temperature range	-40 °C to +70 °C
Humidity range	0 to 100% non-condensing
Ingress Protection (IP) rating	54
Tacho output	Two tacho pulses (5 Volt) per revolution, 8800 pulses per minute (nominal), 146 Hz
Optional cable lengths	10 m, 25 m and 50 m
Increase of air temperature	0.25 K at 0 W heating 1 K at 5.5 W heating
Zero offset A reduction	50% reduction for CMP's
Offset by heating	-2 W/m <sup>2</sup> at 5.5 W heating (CMP11), no offset for CGR pyrometers
Cable resistance	0.16 Ω/m (2 x 0.08 Ω/m)
Voltage drop at maximum heating	0.075 V/m
Size	0.23 m diameter, length 0.355 m
Advantages	Easier filter access No build-up of snow under ventilator (hangs over mounting platform/located higher) Easy removal of cover Because of radial ventilator, 5x better circulation of air over the top of the dome Lower power consumption for both ventilator and heater with improved performance Wide operating voltage range High quality cable with very low voltage drop (optional)

Note: The performance specifications quoted are worst-case and/or maximum values

### 5.2 Dimensions and weight

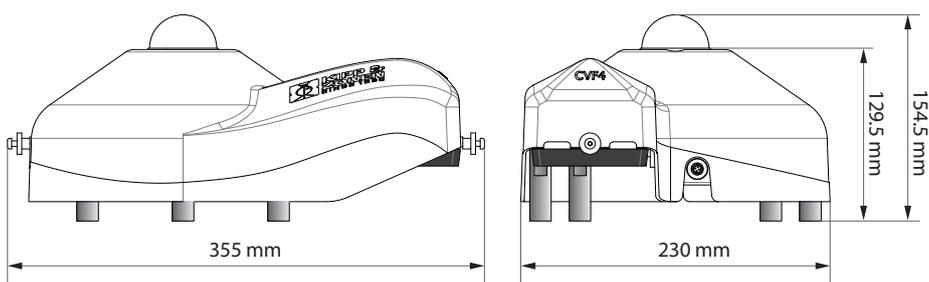

Weight without cable: 1.6 kg



## 6. Trouble shooting

Malfunction	Cause	Check
Ventilator and heater do not work	Power failure	Check 12 VDC and/or mains voltage
Ventilator does not work	Mechanical obstruction	Clean filter and/or remove obstruction
Ventilator does not work	Electrical failure	Check fan impedance $\sim 30 \Omega$
Heater does not work	Resistor defective	Measure power resistors: Specifications: 15 Watt and $50 / 39 \Omega$



## 7. Customer support

If you require any support for your Kipp & Zonen product please contact your local representative in the first instance. The information can be found in the 'Contact' section of our website at [www.kippzonen.com](http://www.kippzonen.com).

Alternatively, you can contact us directly at [www.kippzonen.com/support](http://www.kippzonen.com/support)

Please include the following information:

- Instrument model
- Instrument serial number
- Details of the fault or problem
- Examples of data files
- Readout device or data acquisition system
- Interfaces and power supplies
- History of any previous repairs or modifications
- Pictures of the installation
- Overview of the local environment conditions

Kipp & Zonen guarantees that your information will not be shared with other organisations.



**KIPP &  
ZONEN**  
SINCE 1830

Our customer support remains at your disposal for any maintenance or repair, calibration, supplies and spares.

Für Servicearbeiten und Kalibrierung, Verbrauchsmaterial und Ersatzteile steht Ihnen unsere Customer Support Abteilung zur Verfügung.

Notre service 'Support Clientèle' reste à votre entière disposition pour tout problème de maintenance, réparation ou d'étalonnage ainsi que pour les accessoires et pièces de rechange.

Nuestro servicio de atención al cliente esta a su disposición para cualquier actuación de mantenimiento, reparación, calibración y suministro de repuestos.

## HEAD OFFICE

Kipp & Zonen B.V.  
Delftechpark 36, 2628 XH Delft  
P.O. Box 507, 2600 AM Delft  
The Netherlands

+31 15 275 5 210  
info@kippzonen.com  
www.kippzonen.com

## SALES OFFICES

Kipp & Zonen France S.A.R.L.  
88 Avenue de l'Europe  
77184 Emerainville  
France

T: +33 (0) 1 64 02 50 28  
F: +33 (0) 1 64 02 50 29  
kipp.france@kippzonen.com

Kipp & Zonen Asia Pacific Pte. Ltd.  
10 Ubi Crescent Lobby E  
#02-93 Ubi Techpark  
Singapore 408564

T: +65 (0) 6748 4700  
F: +65 (0) 6748 6098  
kipp.singapore@kippzonen.com

Kipp & Zonen USA Inc.  
125 Wilbur Place  
Bohemia NY 11716  
United States of America

T: +1 (0) 631 589 2065  
F: +1 (0) 631 589 2068  
kipp.usa@kippzonen.com

Go to [www.kippzonen.com](http://www.kippzonen.com) for your local distributor or contact your local sales office

Passion for Precision